

HPI-CLP-25

Hendrix Clamp Line Post Insulators are molded from a proprietary blend of gray, track and UV resistant, high-density polyethylene. They are more durable and reliable than traditional porcelain insulators.

The HPI-CLP-25 is a universal clamp top design with a steel base and center tap $\frac{3}{4}$ " thread size. It meets the electrical and mechanical requirements of ANSI C29.7 and C29.18. It is a direct replacement for high-voltage porcelain or composite insulators.

- Lighter than porcelain
- Designed for use in vertical and horizontal configurations
- Resistant to impact damage, breakage and vandalism
- Molded in USA

PRODUCT DATA

Characteristic	ANSI C29.7 57-14 & 24	ANSI C29.18 51-15 & 25	HPI-CLP-25
DIMENSIONS			
Leakage Distance (in)	40	42	59.4
Dry-arc Distance (in)	14.5	17.25	18.8
Center-hole Diameter (in)	0.75	0.75	0.75
MECHANICAL VALUES			
Specified Cantilever Load (lbs)	2800	2400	>2800
Max Design Cantilever Load (lbs)	1400 ^[1]	1200	1400 ^[2]
Specified Tensile Load (lbs)	N/A	5000	>5000
ELECTRICAL VALUES			
Typical Application (kV)	69	69	69
Flashover, 60 Hz Dry (kV)	140	160	187
Flashover, 60 Hz Wet (kV)	110	130	151
Impulse Flashover – Positive (kV)	230	265	335
Impulse Withstand – Positive (kV)	-	-	308
Impulse Flashover – Negative (kV)	-	-	-486
Max RIV (μ V) tested at 44 kV	200	200	2.2
OTHER			
Min.-Max. Conductor Diameter (in)	-	-	.187 - 1.3
Part Weight (lbs)	~26	-	15.75

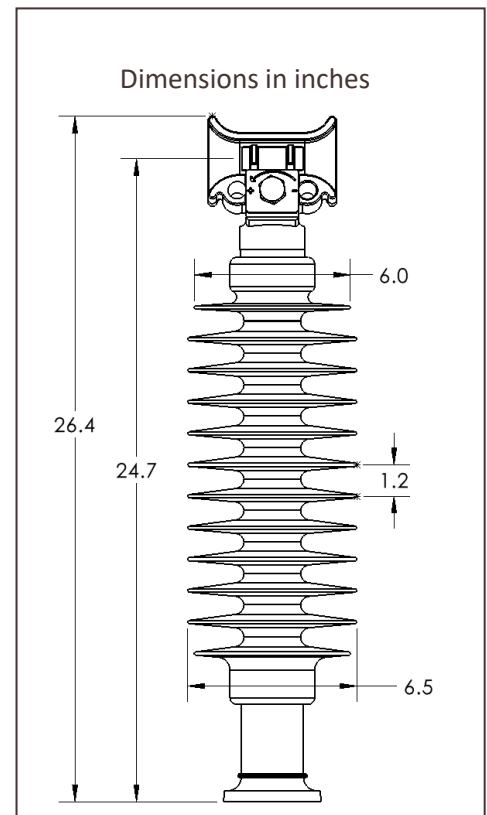

NOTES: [1] Wet-process porcelain insulators are proof tested at 40% of Rated Cantilever Strength

[2] MDCL is specified by the manufacturer

[3] Patent Pending