



Description

The BT3-35 is a transformer tap bracket used with Hendrix Spacer Cable Systems. The bracket is formed using 4.0" channel and includes welded gussets for maximum strength. The bracket is hot dip galvanized after fabrication.

Benefits

- ◇ Increased phase separation provides more working clearance and facilitates stripping the phase conductors for tap connections.
- ◇ Maintains the triangular configuration of the phase conductors.
- ◇ Reduces movement of phase conductors due to wind thereby reducing the stress on transformer tap wires.
- ◇ 8.0" mounting hole spacing conforms to standard pre-drilled poles for ease of installation.
- ◇ Ground Lug Provision.

Application

The BT3-35 tap bracket can be used on any structure where the line angle does not exceed 60° and increased phase separation is desirable (provides more spacing than the BA3-15 and BA3-35 brackets). The bracket should be applied along with Hendrix HPI polyethylene insulators and covered tie wire or HPI Vise-Top Insulators. Pole mounting is accomplished using thru-bolts (not included).

BT3-35

Technical Specifications

System Application

Bracket Type:	Angle Bracket
Bracket Length:	38.5"
Maximum System Voltage (kV):	46
Line Angle (degrees):	0-60

Dimensions

Overall Dimensions (in): 38.5 x 21.168 x 4

Other

Material:	ASTM A-36 Structural steel
Finish:	HDG
Weight (lbs.):	42.0

Additional Information

[Link to 3D Product Image](#)

Dimensions

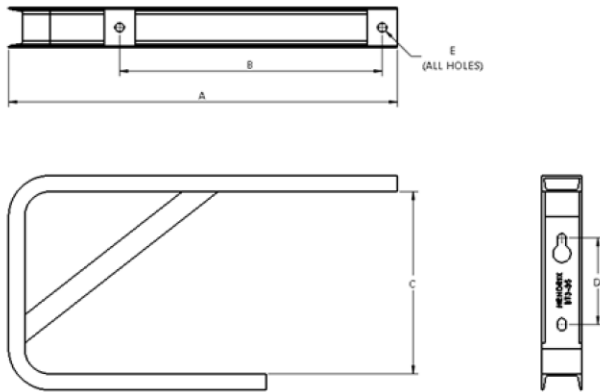

Dimensions (inches):

A	B	C	D	E
38.5	26	18	8	0.8125

Application

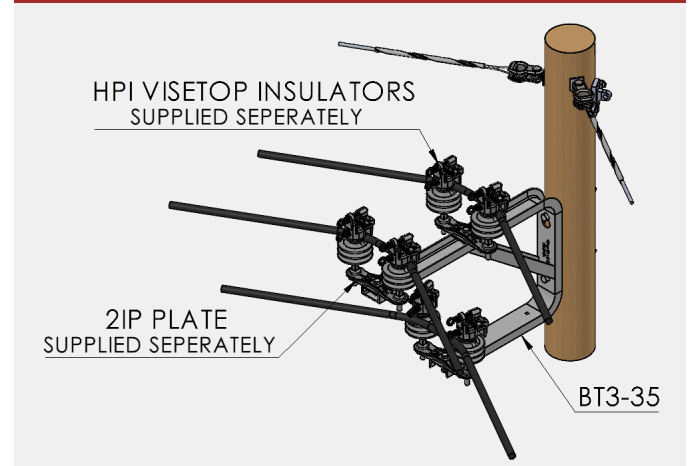

SYSTEM VOLTAGE	LINE ANGLE	CONDUCTOR SIZE	2IP PLATES
15kV	7° - 60°	ALL CONDUCTORS	NOT REQUIRED
25/35kV	7° - 44°	ALL CONDUCTORS	NOT REQUIRED
	45° - 60°	BELOW 336.4	NOT REQUIRED
	45° - 60°	336.4 AND LARGER	NOT REQUIRED