

PROPRIETARY AND CONFIDENTIAL

THE INFORMATION CONTAINED IN THIS DRAWING IS THE SOLE PROPERTY OF MARMON UTILITY, LLC. REPRODUCTION IN PART OR AS A WHOLE WITHOUT THE WRITTEN PERMISSION OF MARMON UTILITY, LLC IS PROHIBITED.

TECHNICAL SPECIFICATIONS

MECHANICAL VALUES

SAFE WORKING LOAD (LBS)

2,500

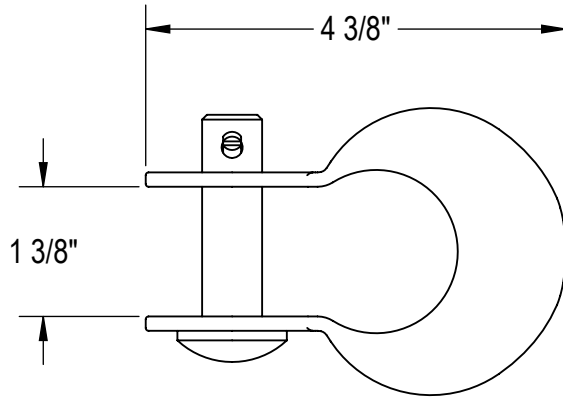

TOP VIEW

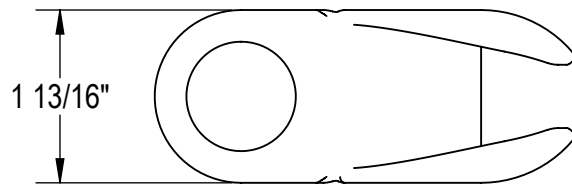
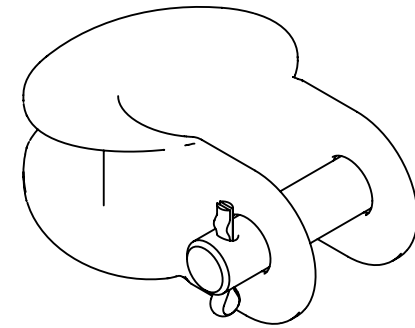

FRONT VIEW

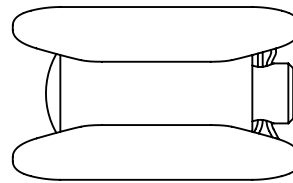

RIGHT VIEW



AERIAL CABLE SYSTEMS

53 Old Wilton Road, Milford, NH 03055 (603) 673-2040 www.marmonutility.com

CLEVIS - THIMBLE

UNLESS OTHERWISE SPECIFIED
DIMENSIONS ARE IN INCHES

MATERIAL

STRUCTURAL STEEL

FINISH

HOT-DIPPED GALVANIZED, ASTM A123

SIZE | PART NBR

A | TC

REV

0

SCALE: 1:2

WEIGHT: 1.2

SHEET: 1 OF 1