

**PROPRIETARY AND CONFIDENTIAL**

THE INFORMATION CONTAINED IN THIS DRAWING IS THE SOLE PROPERTY OF MARMON UTILITY, LLC. REPRODUCTION IN PART OR AS A WHOLE WITHOUT THE WRITTEN PERMISSION OF MARMON UTILITY, LLC IS PROHIBITED.

**TECHNICAL SPECIFICATIONS**

**MECHANICAL VALUES**

MINIMUM ULTIMATE LOAD (LBS)	40,000
-----------------------------	--------

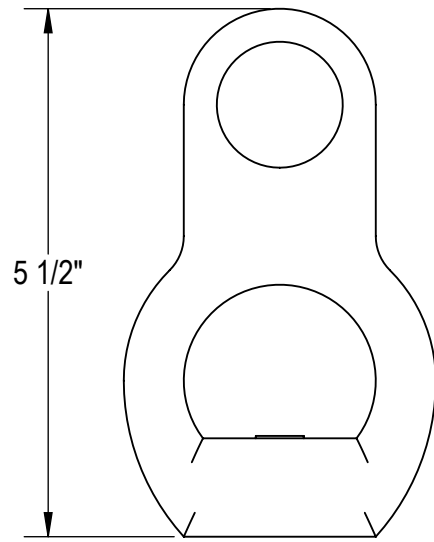

TOP VIEW

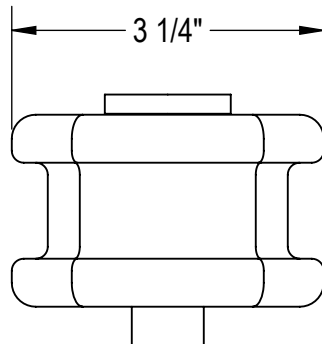
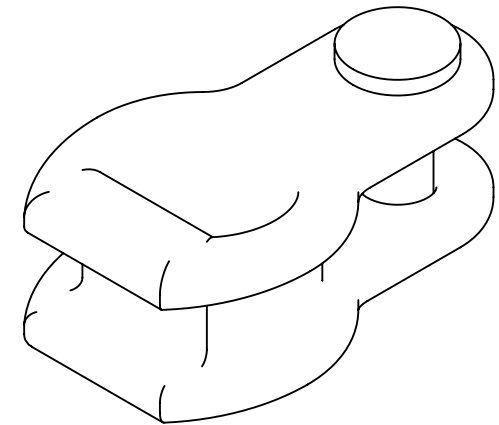

FRONT VIEW

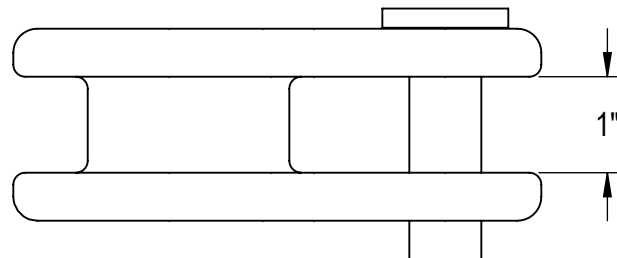

RIGHT VIEW



53 Old Wilton Road, Milford, NH 03055 (603) 673-2040 www.marmonutility.com

**THIMBLE CLEVIS - 40,000 LBS.**

\*\*\*UNLESS OTHERWISE SPECIFIED\*\*\*  
DIMENSIONS ARE IN INCHES

MATERIAL  
DUCTILE IRON

FINISH  
HOT-DIPPED GALVANIZED

SIZE	PART NBR	REV
A	HDTC	

SCALE: 1:2	WEIGHT: 2.75 LBS	SHEET: 1 OF 1
------------	------------------	---------------