

PROPRIETARY AND CONFIDENTIAL

THE INFORMATION CONTAINED IN THIS DRAWING IS THE SOLE PROPERTY OF MARMON UTILITY, LLC. REPRODUCTION IN PART OR AS A WHOLE WITHOUT THE WRITTEN PERMISSION OF MARMON UTILITY, LLC IS PROHIBITED.

TECHNICAL SPECIFICATIONS

MECHANICAL VALUES

MINIMUM ULTIMATE LOAD (LBS)	11,000
MAXIMUM LINE ANGLE (DEG)	60

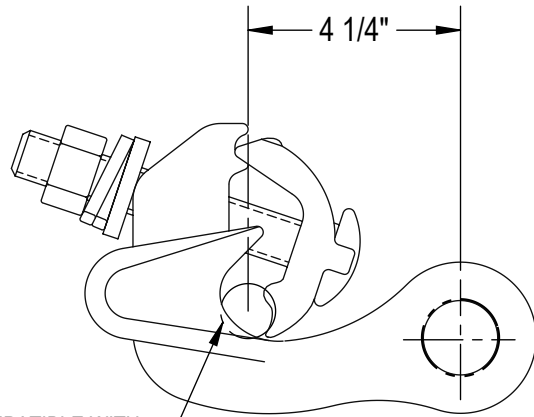
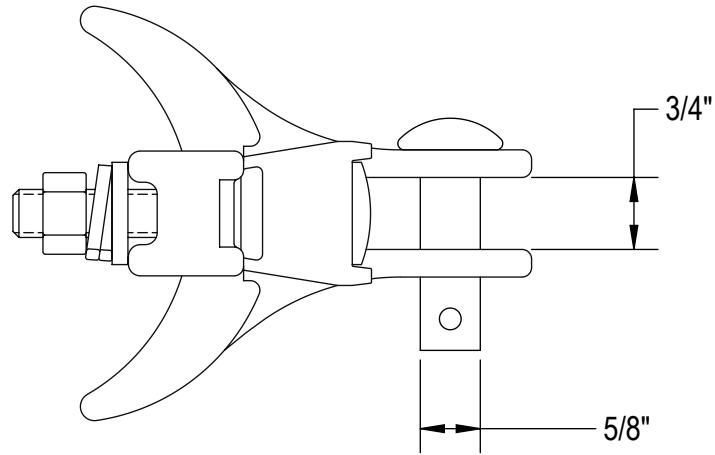

COMPATIBLE WITH
MESSENGER ϕ .16 - ϕ .75



53 Old Wilton Road, Milford, NH 03055 (603) 673-2040 www.marmonutility.com

CLAMP - ANGLE SUSPENSION

UNLESS OTHERWISE SPECIFIED
DIMENSIONS ARE IN INCHES

MATERIAL	DUCTILE IRON
FINISH	HOT-DIPPED GALVANIZED

SIZE	PART NBR	REV
A	CMA-2	

SCALE: 1:2 WEIGHT: 2.00 SHEET: 1 OF 1