

**PROPRIETARY AND CONFIDENTIAL**  
 THE INFORMATION CONTAINED IN THIS DRAWING IS THE SOLE  
 PROPERTY OF MARMON UTILITY, LLC. REPRODUCTION IN PART  
 OR AS A WHOLE WITHOUT THE WRITTEN PERMISSION OF  
 MARMON UTILITY, LLC IS PROHIBITED.

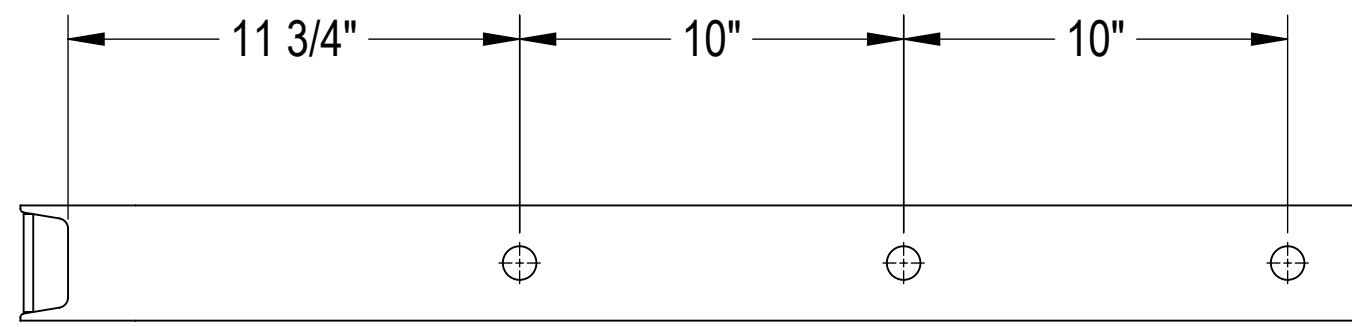

**TOP VIEW**

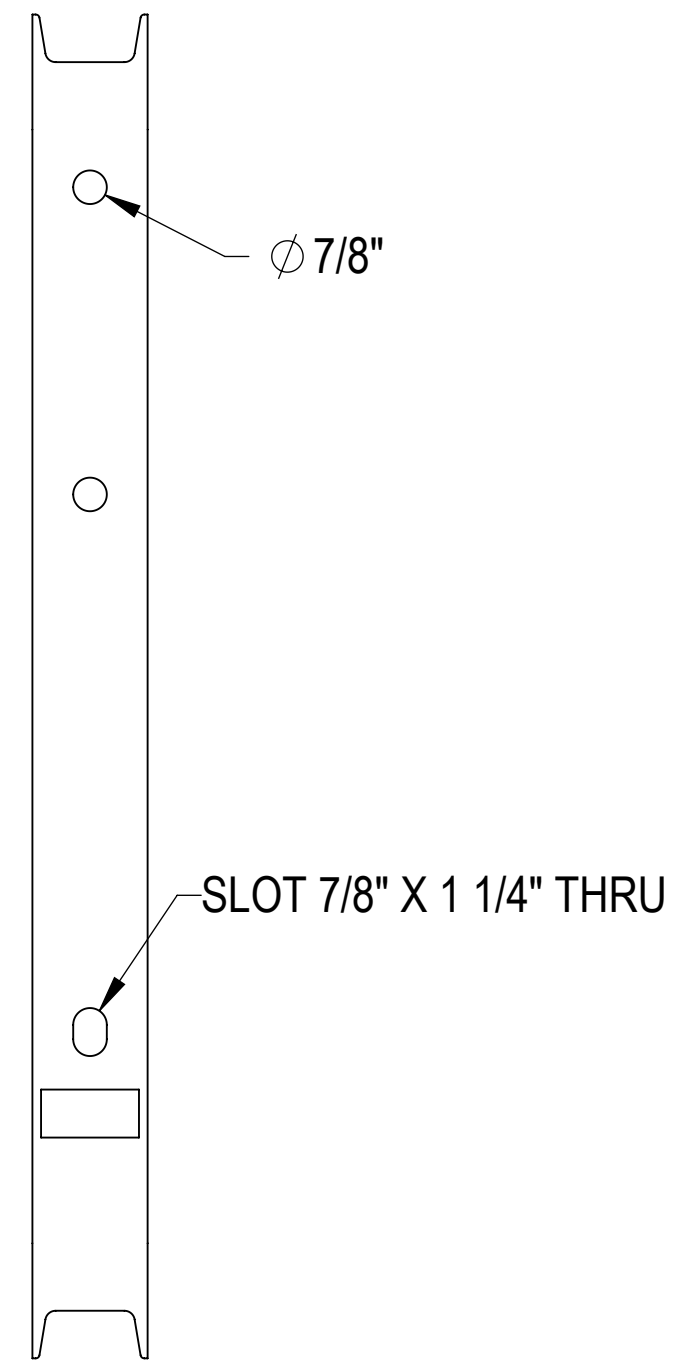
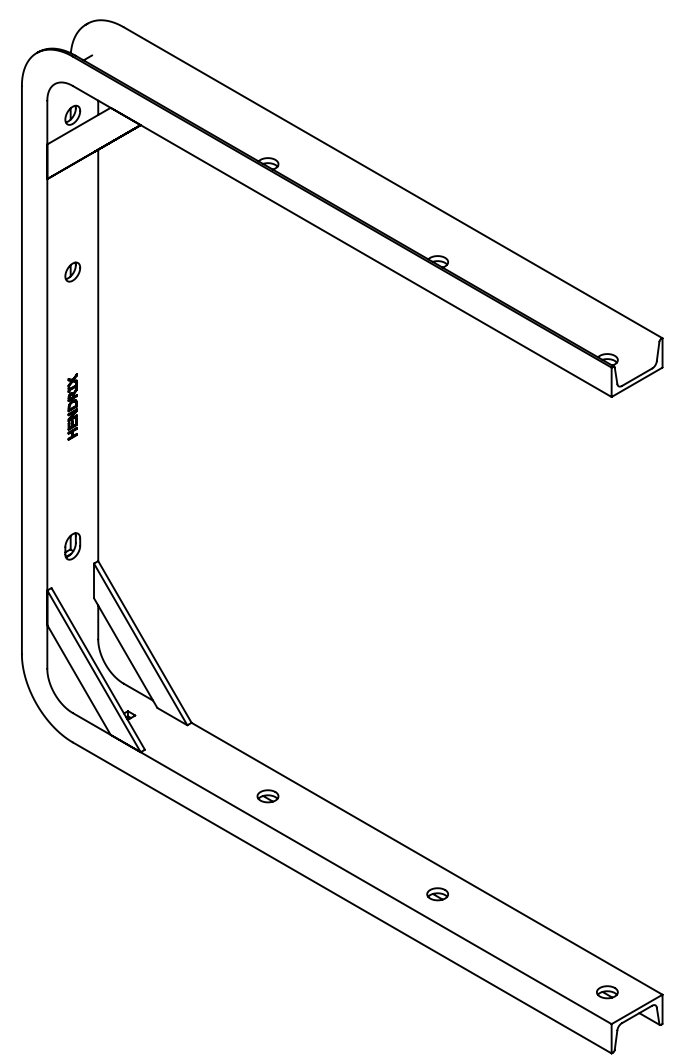

**LEFT VIEW**

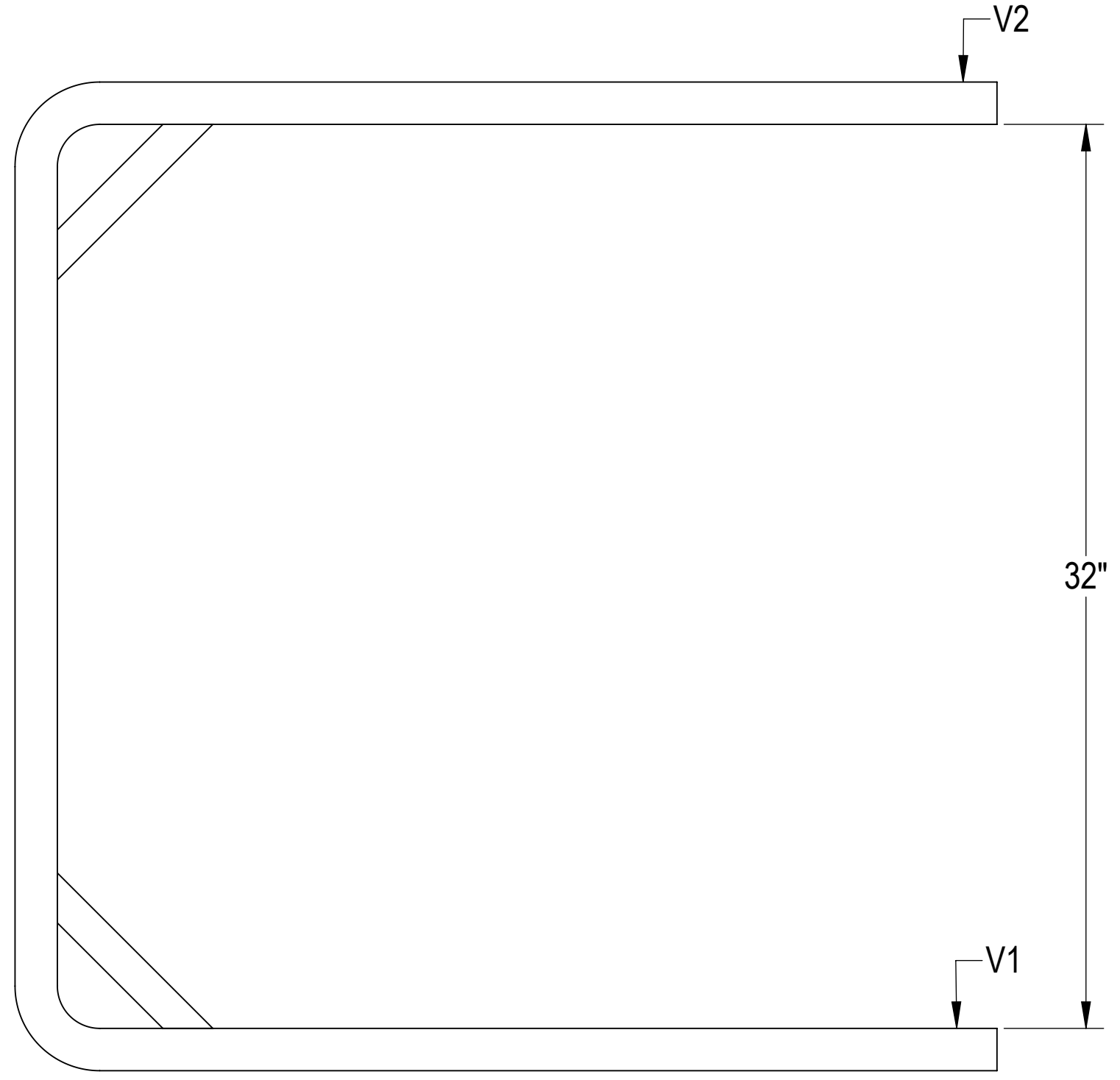

**FRONT VIEW**

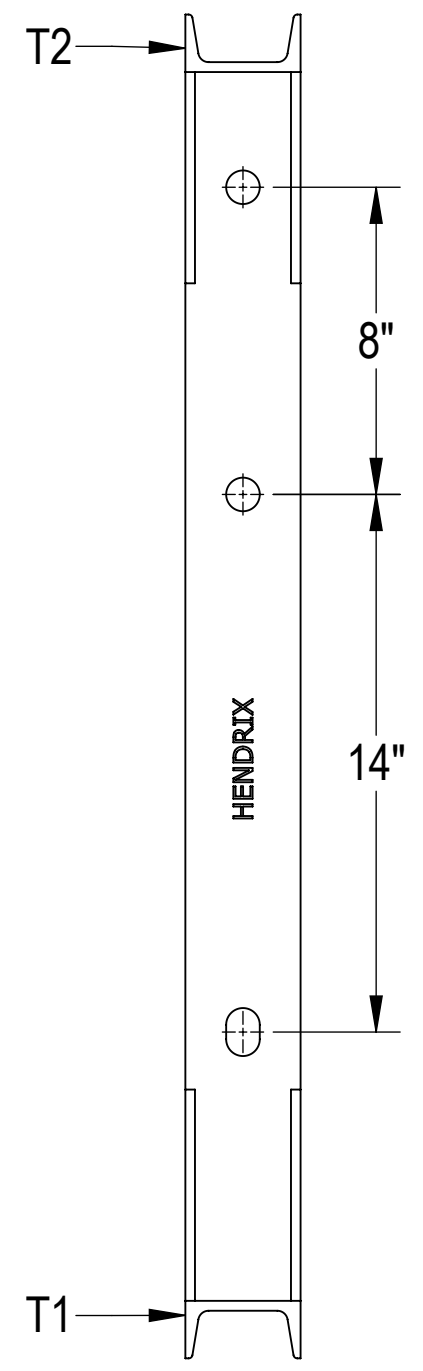

**RIGHT VIEW**

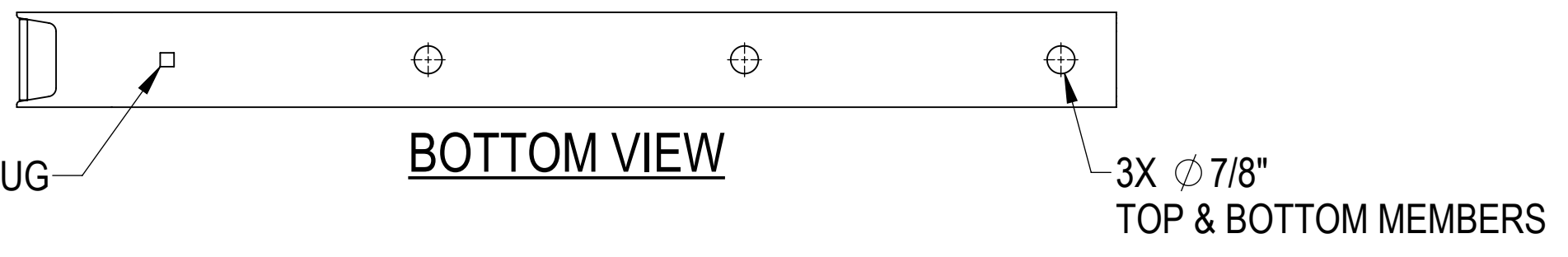

**BOTTOM VIEW**

RATING		
	MECHANICAL STRENGTH	MINIMUM YIELD
V1	VERTICAL LOAD	850
V2	VERTICAL LOAD	850
T1	TRANSVERSE LOAD	300
T2	TRANSVERSE LOAD	300

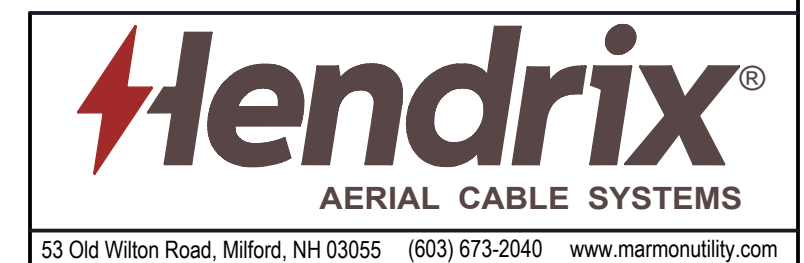

***UNLESS OTHERWISE SPECIFIED*** DIMENSIONS ARE IN INCHES	
MATERIAL	STRUCTURAL STEEL
FINISH	HOT-DIPPED GALVANIZED, ASTM A123

BRACKET - DOUBLE CIRCUIT		
SIZE	PART NBR	REV
C	BA6-15	4
SCALE: 1:5	WEIGHT: 37.00 LBS	SHEET: 1 OF 1