

# Vise Top Stringing Tool

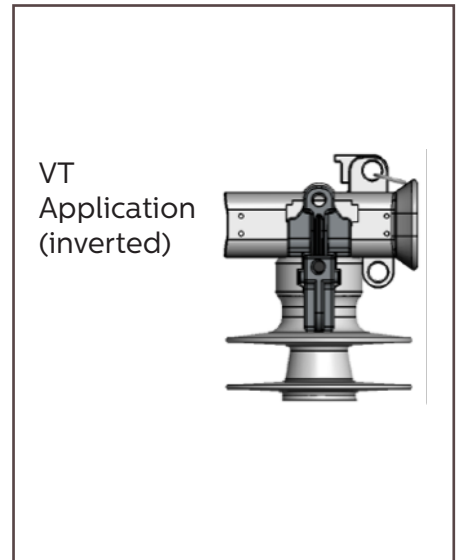

## VTST-2

The VTST-2 is a second generation design optimized for rugged field use with all Vise Top style pin type insulators. It is designed to sit in the insulator's jaw platform and is removable by hand or live-line tool (hot stick). It is made from abrasion-resistant, glass-filled nylon to support numerous installations.

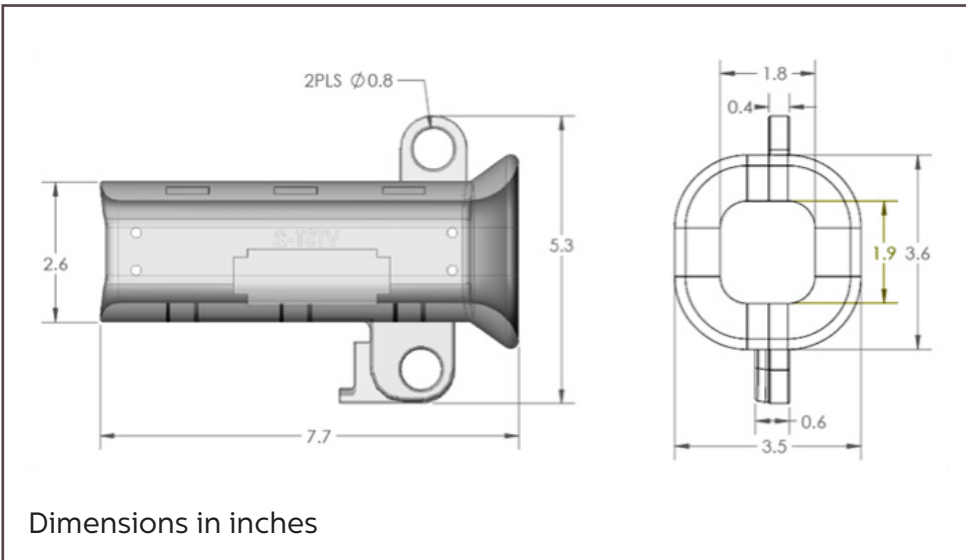

Model	Description
VTST-1	First generation, round two piece, glass filled nylon construction with zinc-plated coupling ring
VTST-2	Second generation, square, two piece, glass filled nylon construction elongated bod with zinc-plated coupling ring