

## Description

The PSAC-01 is a combination stringing block and messenger clamp used with Hendrix Spacer Cable Systems. The messenger clamp is designed for use in distribution systems rated up to and including 46kV. Mounted on angle poles, the PSAC-01 will function as an installation device and also secure the messenger wire to the pole. The PSAC-01 is cast structural steel and hot dipped galvanized after fabrication.

## Benefits

- ◆ Acts as a stringing block to install messenger wire
- ◆ Built-in clamp secures the messenger once it is tensioned
- ◆ Saves time by eliminating the need to relieve messenger tension, removing block and install messenger clamp
- ◆ High strength design will support our largest size spacer cable systems
- ◆ Reduced handling of messenger wire

## Application

Use the PSAC-01 on angle poles (line angles 7-60°) in distribution systems rated up to and including 46kV. The PSAC-01 is designed to be attached directly to the pole with an eye bolt. The PSAC-01 can also be attached to the BA4-15 or BA4-35 bracket for angles that pull away from the pole. The PSAC-01 is designed for pulling grips and swivels up to 1.25 inch diameter.

# PSAC-01

Technical Specifications

## System Application

**Hardware Type:** Angle Clamp  
**Maximum System Voltage (kV):** 46  
**Line Angle (degrees):** 7-60  
**Max. Messenger Size (in):** .75

## Dimensions

**Overall Dimensions (in):** 7-3/4 x 3-1/2 x 3-1/2

**Material:**  
**Finish:**  
**Weight (lbs):**

**Other**  
Steel  
HDG  
9

## Additional Information

Link to 3D Product Image: <https://a360.co/2T4InVr>

Maximum Load Rating (lbs)
20,000

## Dimensions

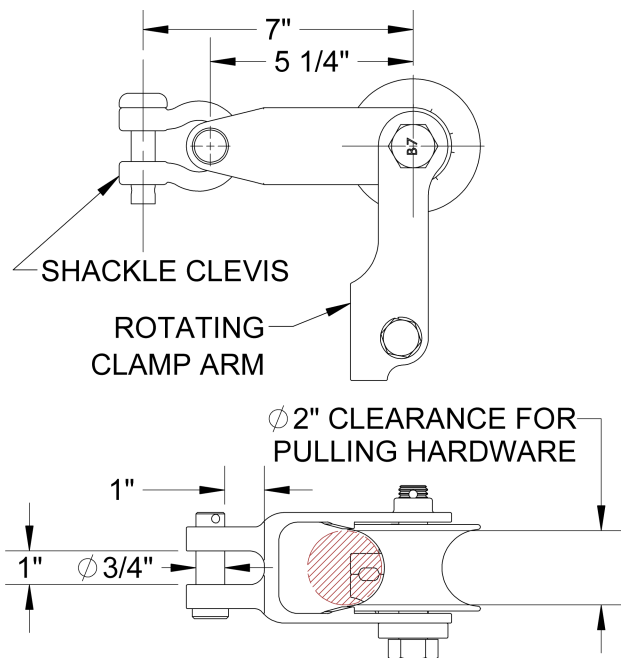

## Application

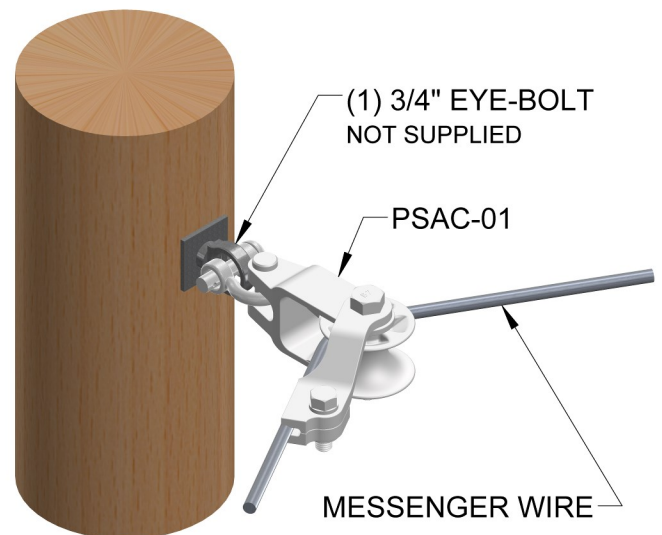

R00