



HPI-LP-9F

Hendrix Line Post Insulators are molded from a proprietary blend of gray, track and UV resistant, high density polyethylene. They are more durable and reliable than traditional porcelain insulators. They are also lighter, safer and easier to handle.

The HPI-LP-9F is the lightest weight insulator in its category. It is a tie-top design with a standard ANSI "F" neck, aluminum base and center tap 3/4" thread size. It meets the electrical and mechanical performance requirements for RUS 12.5kV systems and for ANSI C29.18 Class 51-1F. It is a direct replacement for high-voltage porcelain or composite insulators.



- Easy handling – Lighter than porcelain and composite designs
- Designed for use with all Tie Products and conductor types
- Resistant to impact damage, breakage and vandalism
- RUS Accepted
- Manufactured in USA

PRODUCT DATA

Characteristic	RUS 12.5/7. 2	ANSI C29.18 51- 1F	HPI-LP-9F
DIMENSIONS			
Neck Designation	F	F	F
Leakage Distance (in)	10	10	12.5
Dry-arc Distance (in)		5.2	7.8
Center-hole Diameter (in)	0.75	0.75	0.75
MECHANICAL VALUES			
Specified Cantilever Load (lbs)	1875	2400	2400
Maximum Design Cantilever Load (lbs)	937 ^[1]	1200	1400 ^[2]
Specified Tensile Load (lbs)	N/A	2000	>3000
ELECTRICAL VALUES			
Typical system application (kV)	12.5	15	15
Flashover, 60 Hz Dry (kV)	70	55	89
Flashover, 60 Hz Wet (kV)	50	30	59
Impulse Flashover – Positive (kV)		95	150
Impulse Flashover – Negative (kV)			-222
Max RIV (µV) tested at 10KV	100	100	8.5
OTHER			
Min.-Max. Conductor Diameter (in)		Max. 1.75	.187 - 1.75
Part Weight (lbs)	> 7	> 6.5	3.2
Max. Continuous Conductor Temp (°C)			120

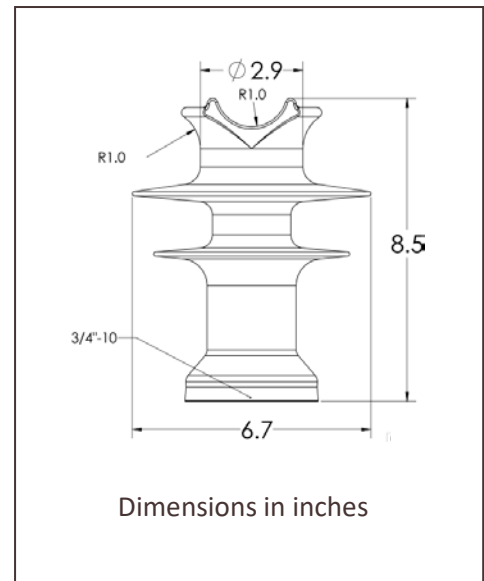

NOTES: [1] Wet-process porcelain insulators are proof tested at 50% of Rated Cantilever Strength
 [2] MDCL is specified by the manufacturer
 [3] IIS Patent No. 9,649,797