



HPI-LP-14FS

Hendrix Line Post Insulators are molded from a proprietary blend of gray, track and UV resistant, high density polyethylene. They are more durable and reliable than traditional porcelain insulators. They are also lighter, safer and easier to handle.

The HPI-LP-14FS is a vertical tie-top design with a standard ANSI “F” neck, steel base and center tap 3/4” thread size. It meets the electrical and mechanical requirements of ANSI C29.7 and C29.18. It is a direct replacement for high-voltage porcelain or composite insulators.

- Easy handling – Lighter than porcelain and composite designs
- Designed for use with all Tie Products
- Resistant to impact damage, breakage and vandalism
- Manufactured in USA

PRODUCT DATA

Characteristic	ANSI C29.7 57-3	ANSI C29.18 51-4F	HPI-LP-14FS
DIMENSIONS			
Neck designation	F	F	F
Leakage distance (in)	29	29	32.6
Dry-arc distance (in)	12.25	12.25	13.1
Center-hole diameter (in)	0.75	0.75	0.75
MECHANICAL VALUES			
Specified Cantilever Load (lbs)	2800	2240	3000
Max Design Cantilever Load (lbs)	1400 ^[1]	1120	1400 ^[2]
Specified tensile load (lbs)	N/A	2000	>3000
ELECTRICAL VALUES			
Typical application (kV)	25/35	25/35	25/35
Flashover, 60 Hz Dry (kV)	125	125	128
Flashover, 60 Hz Wet (kV)	95	95	94
Impulse Flashover – Positive (kV)	200	200	217
Impulse Flashover – Negative (kV)			-365
Max RIV (µV) tested at 22KV	100	100	19.5
OTHER			
Min.-Max. Conductor Diameter (in)	Max. 1.75	Max. 1.75	.187 - 1.75
Part Weight (lbs)	>24	>12	9.4
Max Continuous Conductor Temp (°C)			120

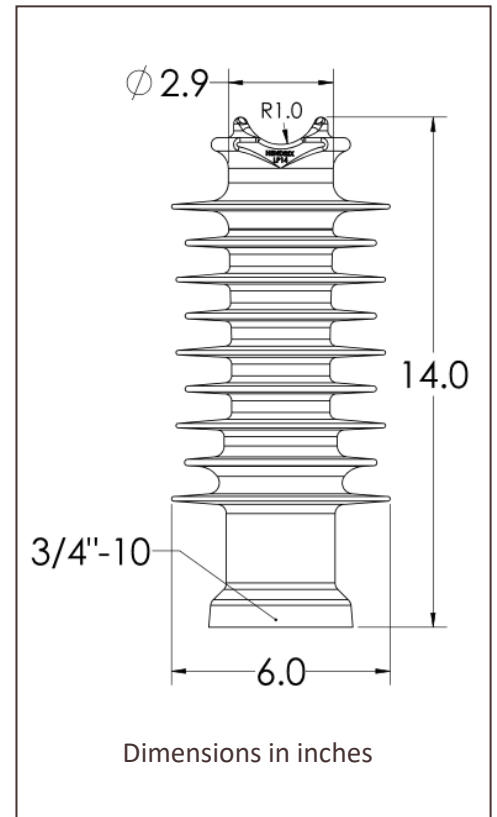

NOTES: [1] Wet-process porcelain insulators are proof tested at 50% of Rated Cantilever Strength
 [2] MDCL is specified by the manufacturer