

Cable Restraint Insulators



HPI-CRI-U

The Cable Restraint Insulator is designed for cable mounting and training in vault, switching cabinet, rack and riser applications. It is molded from a proprietary blend of UV resistant polymers, making it ideally suited for harsh environments and applications where galvanic corrosion is an issue.

Multiple clamping positions, adjustable from 1-1/4" to 4-5/8" openings, allow for use with different conductor sizes and configurations. One half features a mounting channel in-line with the cable saddle and the other half's channel is perpendicular to the saddle. Both halves are suitable for mounting to Uni-strut, poles, walls or floors.

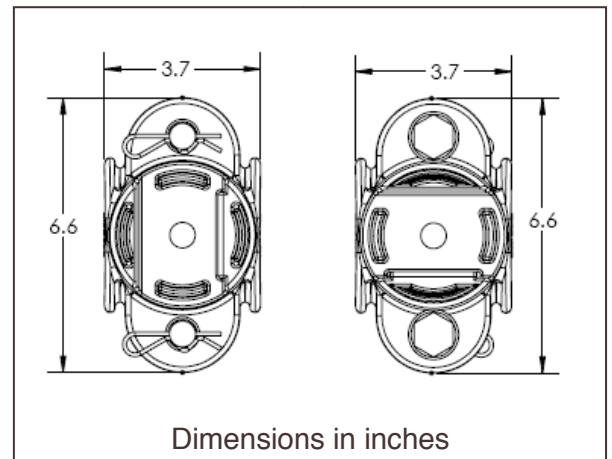
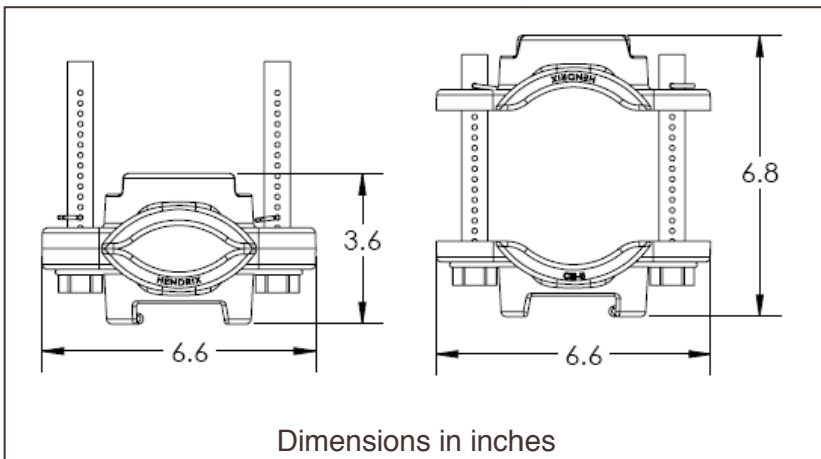

APPLICATIONS

Switchgear



Vault layout



69 kV Riser