



HPI-25J-02

Hendrix Tie Top Insulators are molded from a proprietary blend of gray, track and UV resistant, high density polyethylene. They are more durable and reliable than traditional wet-process porcelain insulators. They are also lighter, safer and easier to handle.

The HPI-25J-02 is designed with standard ANSI neck and thread size. It is a direct replacement for medium and high-voltage porcelain J-neck insulators and recommended for all conductor types, bare or covered.



- Exceeds ANSI electrical and mechanical requirements
- Resistant to impact damage, breakage and vandalism
- Designed for use with all Tie Products
- RUS Accepted
- Made in USA

PRODUCT DATA

Characteristic	ANSI C29.6 Class 56-1	HPI-25J-02
DIMENSIONS		
Neck designation	J	J
Leakage distance (in)	13	14.8
Dry-arc distance (in)	7	8.3
^[1] Pin-hole diameter (in)	1-3/8	1-3/8
MECHANICAL VALUES		
Cantilever strength (lbs)	2500	>3000
ELECTRICAL VALUES		
Typical application (kV)		25
Flashover voltage, 60 Hz Dry (kV)	95	102
Flashover voltage, 60 Hz Wet (kV)	60	75
Impulse Flashover – Positive (kV)	150	170
Impulse Flashover – Negative (kV)	190	200
Low frequency Puncture (kV)	130	227
OTHER		
Min.-Max. Conductor Diameter (in)		.187 - 1.75
Part Weight (lbs)		1.8
^[2] Max Continuous Conductor Temp (°C)		120

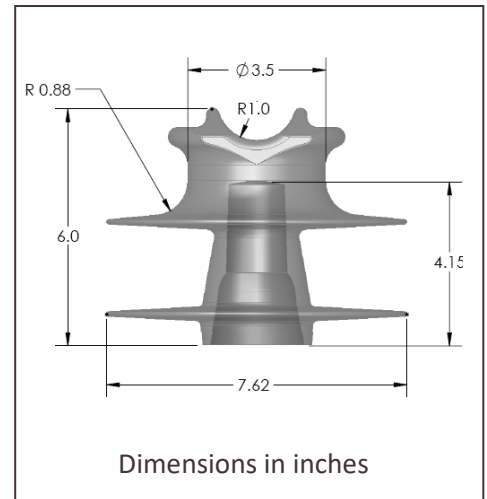

Notes:

[1] Other pin-hole diameters and thread configurations are available

[2] High temperature (200°C) model is available